

TS-Heater 100w TS-Heater 150w 15W to 200W



- Pressure clamp connectors
- Dynamic heating up
- Wide voltage range
- Energy saving
- Clip fixing, Quick installation

These heaters are used in enclosures where damage from condensation must be prevented, or where the temperature may not fall below a minimum value. The aluminium profile heater body design has a chimney effect and distributes the heat evenly. The heaters are designed for permanent operation. Pressure clamp connectors save time and simplify installation.

Technical Data

CE RoHS ISO9001 Patent

TS-Heater 100w / TS-Heater 150w	
Operating voltage	120-240V AC/DC ¹ (min. 110V, max. 265V)
Heating element	PTC resistor - temperature limiting
Heater body	extruded aluminium profile, anodised
Connection	3 pressure clamps for stranded wire 0.5-1.5mm ² (with wire end ferrule) and rigid wire 0.5-2.5mm ²
Connection casing	plastic according to UL94 V-0, black
Mounting	clip for 35mm DIN rail, EN 60715
Fitting position	vertical airflow (air outlet up, connection on bottom)
Operating/Storage temperature	-45 to +70°C (-49 to +158°F)
Operating/Storage humidity	max. 90% RH (non-condensing)
Protection type/Protection class	IP20 / I (earthed)
Accessoires	screw fixing, Art. No. 09024.0-00 (1 packing unit = 2 pieces)
Note	other voltages on request

¹ Operating with voltages below 140V AC/DC reduces heating performance by approx. 10%.

Example of connection

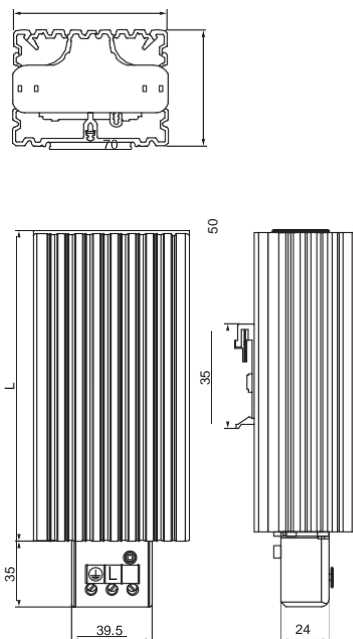
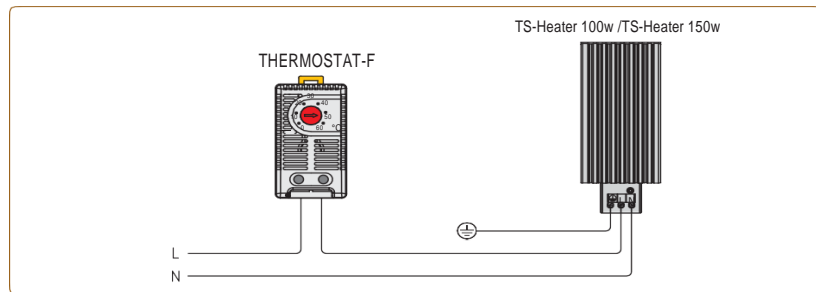

Art. No.	Heating capacity ²	Length (L)	Weight (approx.)
860055	15W	65mm	0.3kg
860056	30W	65mm	0.3kg
860057	45W	65mm	0.3kg
860058	50W	80mm	0.4kg
860059	60W	140mm	0.5kg
860060	75W	140mm	0.5kg
860061	100W	140mm	0.5kg
860062	150W	220mm	0.7kg
860219	200W	220mm	0.7kg

² at +20°C (+68°F) ambient temperature